



Nawiatr – Yacht Building and Design - Piotr Kopczynski

[www.nawiatr.com](http://www.nawiatr.com)

[piotr.kopczynski@nawiatr.com](mailto:piotr.kopczynski@nawiatr.com)

Mob. +48 885 456789

Phone/Fax +48 22 4034243

**Nawiatr N700K** is a fast, coastal racing or weekend cruising catamaran designed and built at the shipyard **Nawiatr** - Yacht Building and Design - Piotr Kopczynski in Warsaw, Poland.

Catamaran was designed in category C according to CE rules for the purpose of navigation in coastal and inland waters.

**Nawiatr N700K** is dedicated for sailors who appreciate active recreation on the water and the excitement of fast sailing.



Technical specification	
Hulls Length	7.00 m
Beam	4.70 m
Draft	0.25/ 1.25 m
Boat weight	450-600kg
Displacement	1050 kg
Design Cat. CE	C
Crew	4/5
Sails	
- Mainsail	22 m <sup>2</sup>
- Jib	8 m <sup>2</sup>
- Schreecher	18 m <sup>2</sup>
Designer	Piotr Kopczynski

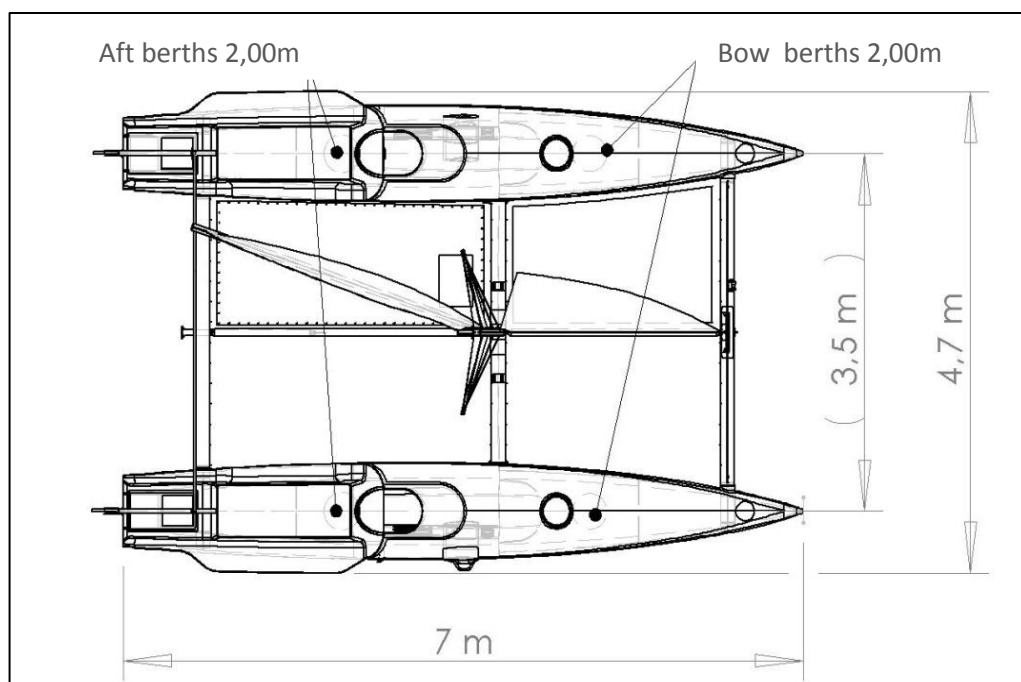

Sport Version of catamaran **Nawiatr N700K** is made in vacuum techniques out of glass, epoxy resin and core material Herex. Due to the technology and materials weight of Sport version does not exceed 550kg with less than 130kg of single hull. Standard version is 100kg heavier.

There are four single berths in two seven meters hulls. On deck layout is simple and easy for the crew to sail the boat efficiently. Mainsheet and traveler are both within arms reach of the helmsman so they can be trimmed or released easily. Yacht is equipped with two symmetrical board plates.

Sport version of catamaran **Nawiatr N700K** due to the sandwich construction is unsinkable. High beams connection give opportunity for fast and dry sailing even on the rough waters. The hulls as well as other parts can be easily separated which gives the flexibility of transportation and selecting sailing spots. The boat could be easily packed into a 40ft container for Overseas buyers. A boat may be equipped with a centrally mounted outboard engine with power of 6 HP.



**Nawiatr N700K** is a fast, coastal racing or weekend cruising catamaran offering new opportunities to spend time on the water. On all points of sail the **Nawiatr N700K** is a pleasure to sail. Tacking is positive with backing of the jib not required. With the speed 20 knots plus, **Nawiatr N700K** outperforms significantly monohull yachts. Catamaran is light enough to be towed behind a compact car and simple enough to be rigged and sailed in under 3 hours. The boat can be launched from a hoist or ramp. Trampoline stretched between the hulls allow for a pleasant relaxing after an exciting sailing and in hot summers nights give possibility to sleep directly under the stars.

**Nawiatr N700K is** a small boat for big adventure!

**Contact details:**

Nawiatr – Yacht Building and Design - Piotr Kopczynski

Pawlaczyka 1/8B ; 02-980 Warsaw ; Poland

[www.nawiatr.com](http://www.nawiatr.com) [piotr.kopczynski@nawiatr.com](mailto:piotr.kopczynski@nawiatr.com)

Mobile phone: +48 885 456789 Phone/Fax. +48 22 4034243

